

June 15, 2026

Ojai Valley Municipal Advisory Council Meeting

Villanova Prep School Sign Variance
Case No. PL26-0010



Resource Management Agency, Planning Division
Noe Torres, Senior Planner

Site Location

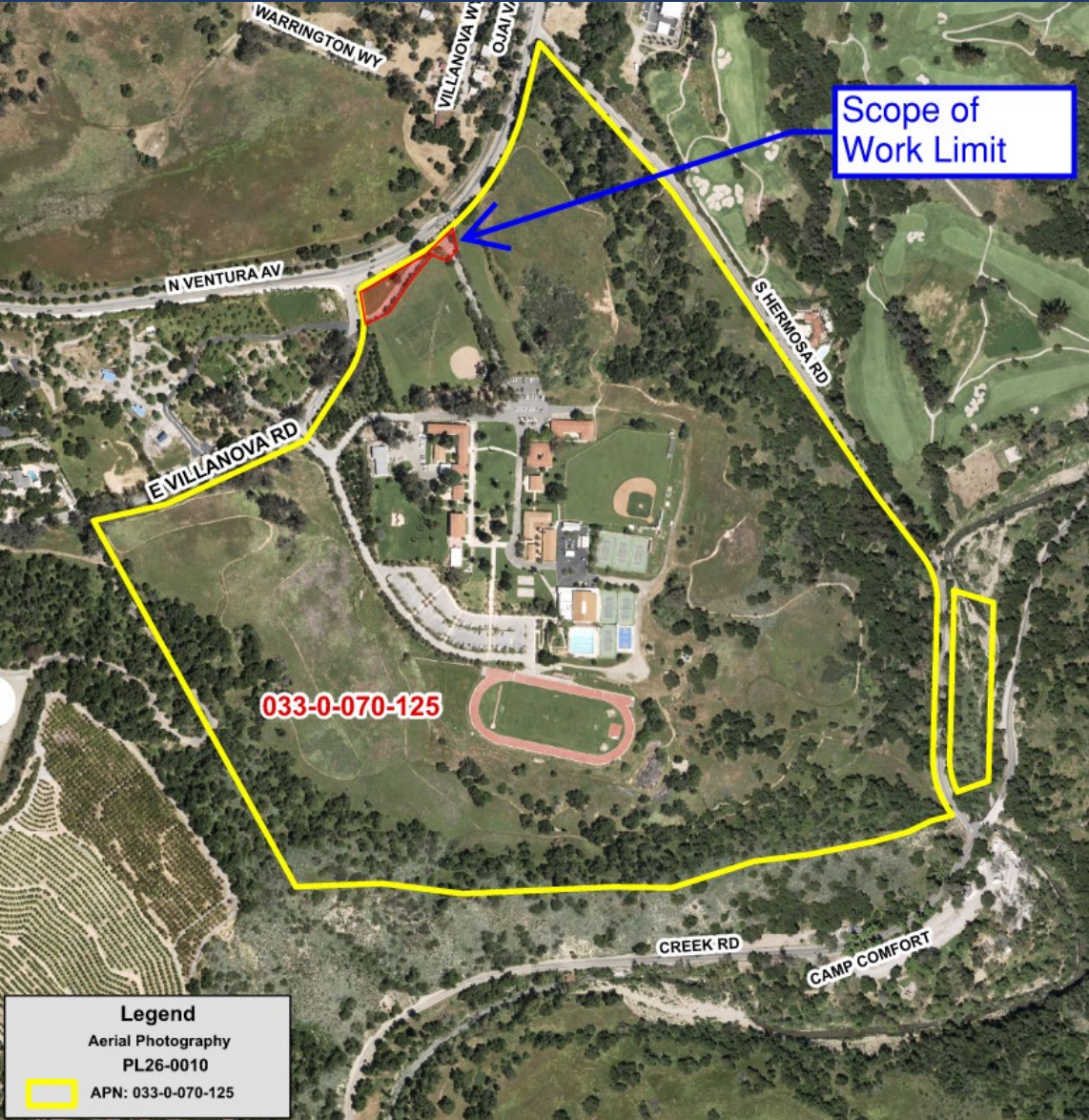

- 12096 North Ventura Ave, Ojai, CA 93023
- **Project Site: 126 acres**

Site Photos



Site Photos



Project Description



- Variance request to authorize deviation from the VC NCZO Section 8110-8.1 and 8110-5.1
 - Waive restriction limiting the number of signs
 - Waive the maximum sign area
- Variance would allow
 - One sign to remain on the property
 - Allow the construction of one new sign
 - 100 sq. ft. in sign area
 - 5 ft maximum height

Site Photos



Project Plans

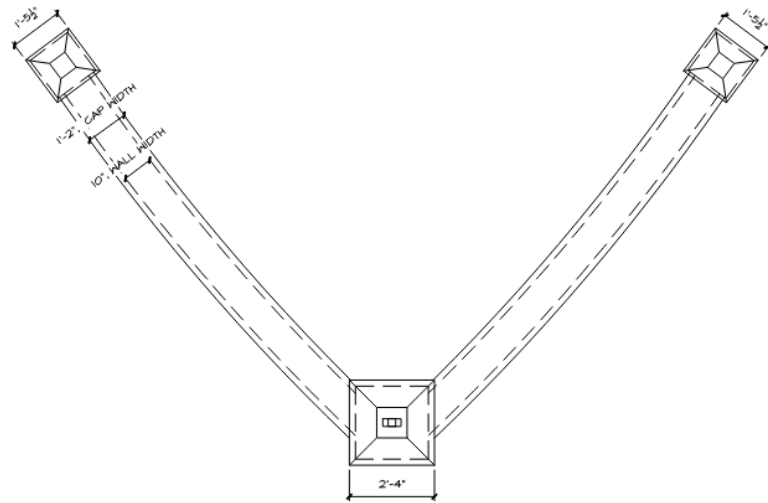

B. PLAN

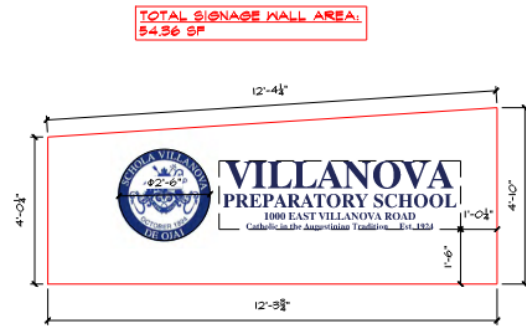

D. SIGNAGE WALL AREA

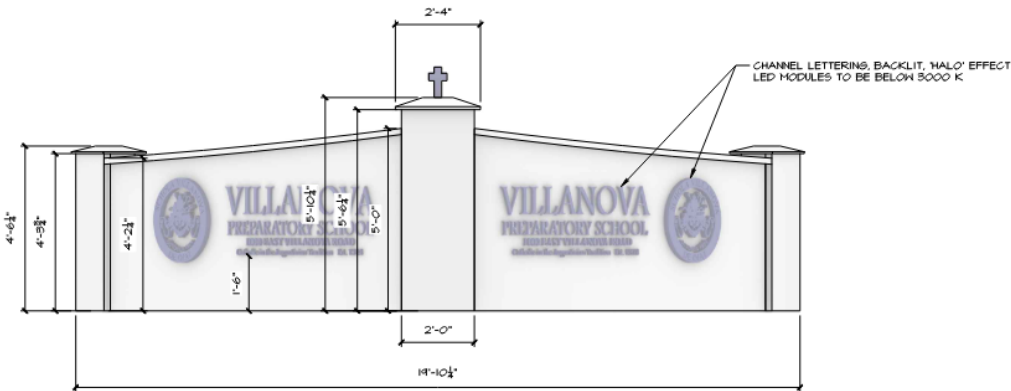

A. FRONT ELEVATION

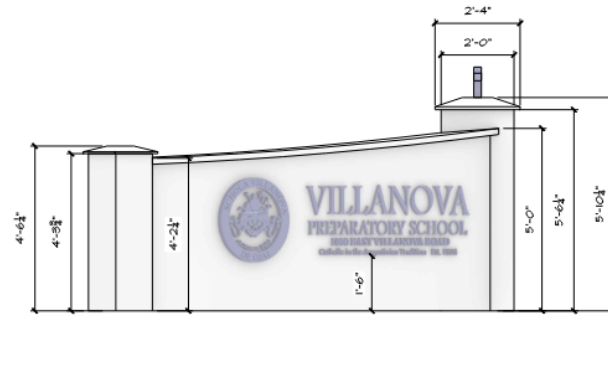

C. SIDE ELEVATION

Project Plans



SITE LEGEND

- PROPOSED COASTAL LIVE OAK
- EXISTING TREES
- LOW MAINTENANCE NATIVE SHRUBS & ACCENTING PERENNIALS
- NATIVE HYDROSEED MIX
- MULCH AREA
- SPLIT RAIL FENCE (5 RAIL)
- EXISTING HIGHWAY BARRIER
- PROPERTY LINE
- SCOPE OF WORK AREA

SIGNAGE WALL CHANNEL LETTERING HALO EFFECT



LED MODULES TO BE BELOW 5,000 KELVIN

Project Plans



VILLANOVA ENTRY SIGNAGE | PLANT LIST

CODE	NATIVE	SIZE	W/ROOTS	BOTANICAL NAME	COMMON NAME
TREES					
QUEAGR	N	4\"/>			

Project Plans

